

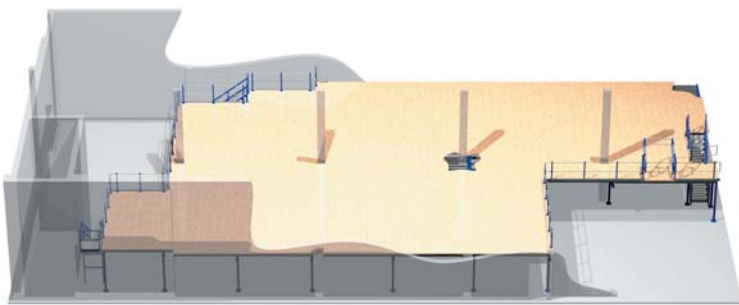

RediFLOOR Accessories:

DESIGN

RediFLOOR



3D solid model of mezzanine and warehouse

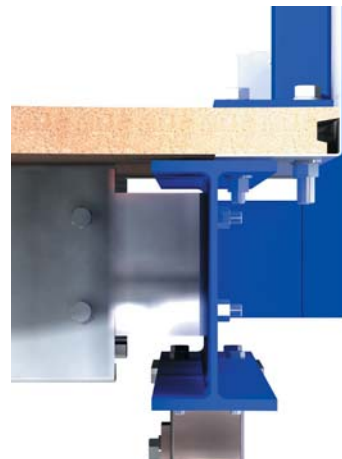

Zoom in to check detail

RediFLOOR - full in-house design for fast, efficient service

Full in-house design service
Building Regulations Approval
Latest 3D solid modelling software

Full laser site surveys
Floor slab checks
Designed for safe installation





RediFLOOR

by **Redirack**

For any number of reasons, not least because you're already heating and lighting it, making the most of the vertical space in your warehouse by installing a mezzanine floor makes perfect sense. 'Expanding up, instead of moving out' can be an extremely cost effective way of creating the space you need quickly and effectively.

Maximise Storage Space

Maybe you want to maximise your storage space or you need more room for your production operation. You may want to upgrade or expand your offices or optimise your retail area? Whatever the reason RediFLOOR can turn your vision into a reality.

And, because of the comprehensive range of services that we are able to offer our clients, you can be confident that we can control the design, manufacture and supply process effectively and professionally.

In-house Design

RediFLOOR provides a full in-house design service enabling us to accelerate design times. All design calculations and drawings are produced in-house by our team of dedicated engineers.

3D Modelling

We use the latest in 3D solid modeling software allowing you to view 3-dimensional rendered images of your floor prior to manufacture. Approved layout drawings can then be instantaneously sent for fabrication at the push of a button.

UK Manufacturer

We can react quickly to additions or variations in design and because we control the manufacturing process you can be confident of receiving a quality product in exceptionally good time.

Building Regulations Approval

All mezzanine floors require Building Regulations Approval. Redirack will be happy to make this application on your behalf if required to do so. Because we are in regular contact with many Building Regulation Approved Inspectors a quick turn around on consultations is assured, giving you access to the latest professional advice prior to order and eliminating the risk of expensive surprises.

Health and Safety

From our initial site survey through to our completion on site, we remain fully committed to health and safety as a top priority. Redirack retain the services of an in-house Health and Safety Principal, so you can be assured that you are in safe hands at all times.

Members of SEMA

As members of SEMA's (Storage Equipment Manufacturers Association) Mezzanine Floor Committee, RediFLOOR representatives are actively promoting best practice within the industry.

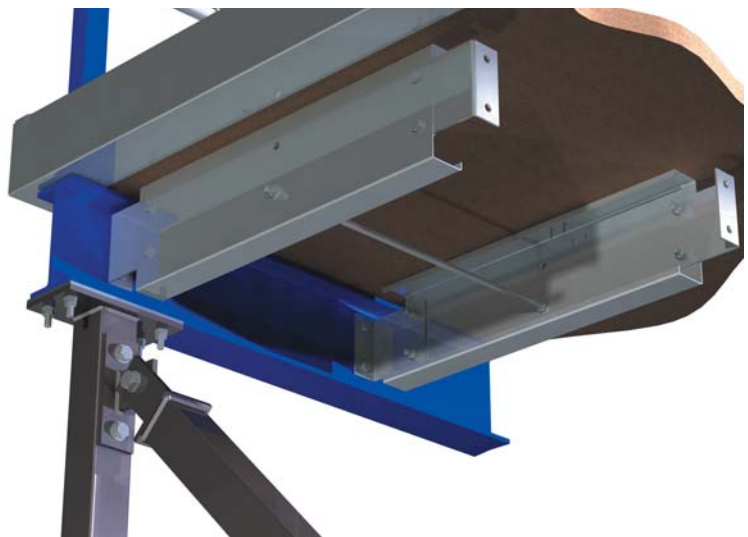

Call us now on 01709 584711